

END SUCTION VOLUTE PUMP

 Model **FSA**
PT. LUKES INDONESIA

 Lindeteves Trade Center Lt UG, Blok B1 No. 6
 Jalan Hayam Wuruk, Jakarta - Indonesia
 Phone : 021 - 6231 7842, 628 5144
 Fax : 021 - 6231 0499
 email : lukes@cbn.net.id

50 Hz

APPLICATIONS

- Industrial use
- Water supply
- Hot and cold water supply
- For swimming pool
- Sprinkling
- Air-conditioning

FEATURES

- Easy maintenance B.P.O (Back Pull Out) feature allows all rotating element to be removed without disconnecting the suction and discharge pipe work.
- Higher operating efficiency over a wider range of capacities, lowers operational cost.
- Non-overload design to ensure stable performance for all applications.
- Wide range application with flow capacity up to 22m³/min
- Higher working pressure up to 16 Bar.

SPECIFICATIONS

Description		Standard		Optional	
		2 poles model	4 poles model	2 poles model	4 poles model
Liquid	Name	Clean water			
	Temperature	0 to 100 °C (32 to 212 °F)			
Max. Working Pressure		10 bar (10.2 kgf/cm ²) for standard flange JIS 10K RF 16 bar (16.3 kgf/cm ²) for standard flange JIS 16K RF		16 bar (16.3 kgf/cm ²)	
Synchronous Speed		3000 min ⁻¹	1500 min ⁻¹		
Installation		Indoors		Outdoors	
Construction	Impeller	Enclosed			
	Shaft seal	Gland Packing		Mechanical seal	
	Sealing	Self flushing		External flushing	
	Bearing	Sealed ball bearing		Oil bath (some models only)	
Flange	Suction & Discharge	Suction < φ 150 mm, except 100x65 FSKA	JIS 10K RF	16 bar : JIS 16K RF; DIN PN-16	
		100x65 FSKA	JIS 16K RF	DIN PN-16	
		Suction = φ 150 mm, except below models	JIS 10K RF	16 bar : JIS 16K RF; DIN PN-16	
		150x100 FSKA, 150x100 FSNA	JIS 16K RF	DIN PN-16	
		Suction = φ 200 mm, except below models	JIS 10K RF	16 bar : JIS 16K RF; DIN PN-16	
200x150 FSNA, 200x150 FSNA	JIS 16K RF	DIN PN-16			
Suction = φ 250	JIS 16K RF			DIN PN-16	
Material	Casing	Cast Iron		Ductile Cast Iron (FCD)	
	Impeller	Bronze Casting (CAC406/BC6)		Cast Iron, Ductile Cast Iron (FCD)	
	Shaft	403 Stainless steel		304, 316 Stainless steel	
	Seal	Mechanical Seal: Ceramic/Carbon/NBR		Gland Packing: Teflon (PTFE) impregnated Mechanical Seal: SiC/SiC	
Accessories	Bare shaft			Priming funnel : valve; Companion Flange	
	With motor	Common base, Coupling, Coupling guard		Priming funnel : valve; Companion Flange	

SECTIONAL VIEW

FSA

DIMENSIONS - BARE SHAFT PUMP

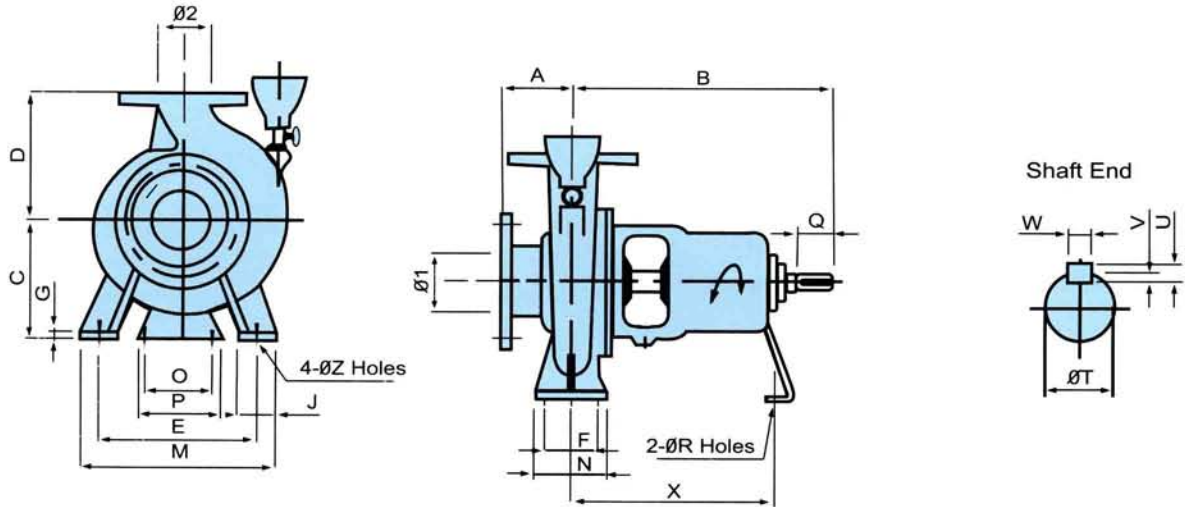

FLANGE JIS 10K RF

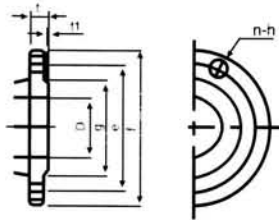

Dimension - Flange

D	f	e	g	t1	t	n	h
mm	mm	mm	mm	mm	mm		mm
40	140	105	81	2	20	4	19
50	155	120	96	2	20	4	19
65	175	140	116	2	22	4	19
80	185	150	126	2	22	8	19
100	210	175	151	2	24	8	19
125	250	210	182	2	24	8	23
150	280	240	212	2	26	8	23
200	330	290	262	2	26	12	23

Dimension - Pump

Model	Size		Pump														Shaft					wt kg										
	$\phi 1$	$\phi 2$	A	B	C	D	E	F	G	J	M	N	O	P	R	X	Z	T	Q	U	V		W									
50x40 FSHA	50	40	80	360	160	180	190	70	12	50	240	100	110	150	17	285	15	24	50	7	4	8	37									
65x50 FSHA	65	50	100	360	160	180	212	70	12	50	265	100	110	150	17	285	15	24	50	7	4	8	42									
65x50 FSJA					180	225	250	95	14	65	320	125											49									
80x65 FSGA	80	65	100	360	160	180	212	70	12	50	265	100	110	150	17	285	15	24	50	7	4	8	39									
80x65 FSHA					200	212	70	12	50	265	100	48																				
80x65 FSJA					180	225	250	95	14	65	320	125											60									
80x65 FSKA					125	470	225	280	315	120	16	80											400	160	370	19	32	80	8	5	10	108
100x80 FSGA	100	80	100	360	160	200	212	95	14	65	280	125	110	150	17	285	15	24	50	7	4	8	49									
100x80 FSHA					180	225	250	15	80	320	125	62																				
100x80 FSJA					200	250	280	120	80	360	160	110											150	17	285	19	32	80	8	5	10	70
100x80 FSGCA					225	250	95	14	65	320	125	62																				
100x80 FSHCA					125	360	180	250	280	95	14	65											345	125	15	32	80	8	5	10	65	
125x100 FSJCA	125	100	140	360	225	280	315	120	16	80	400	160	110	150	17	285	19	32	80	8	5	10	108									
125x100 FSKA				470	250	315	150	20	100	500	200	128																				
125x100 FSLA				530	280	355	400	150	20	100	500	200											168									
150x125 FSHA	150	125	140	470	250	315	315	120	15	80	400	160	110	150	17	370	19	32	80	8	5	10	120									
150x125 FSJA					355	16	100	500	200	110	150	17											370	24	42	110	8	5	12	170		
150x125 FSKA	150	125	140	530	280	355	400	150	16	100	500	200	110	150	17	370	24	42	110	8	5	12	205									
150x125 FSLA					315	400	20	100	500	200	110	150											17	370	24	42	110	8	5	12	205	
200x150 FSHA	200	150	160	470	280	355	400	150	18	100	500	200	110	150	17	370	24	32	80	8	5	10	137									
200x150 FSJA	200	150	160	530	280	375	400	150	18	100	500	200	110	150	17	370	24	42	110	8	5	12	183									
200x150 FSKA				670	315	400	450	20	100	550	200	140											180	19	500	48	9	5.5	14	222		

Unit:mm, unless otherwise stated

BARE SHAFT PUMP

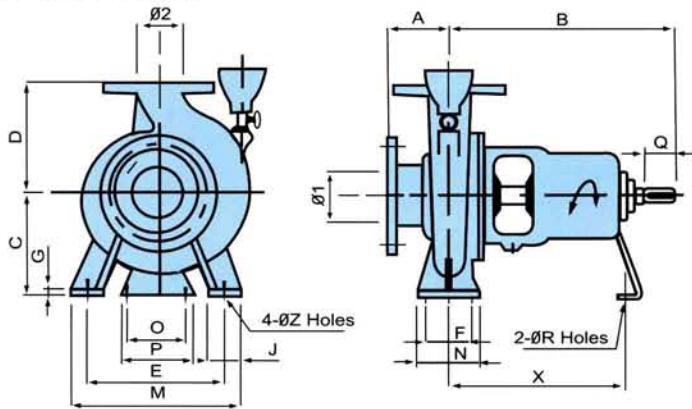

Shaft End

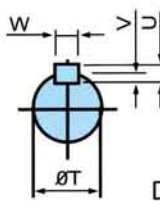

FLANGE JIS 16K RF

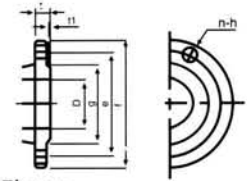

Dimension - Flange

D mm	f mm	e mm	g mm	t1 mm	t mm	n	h mm
65	175	140	116	2	22	8	19
100	225	185	160	2	26	8	23
150	305	260	230	2	28	12	25
200	350	305	275	2	30	12	25
250	430	380	345	2	34	12	27

Dimension - Pump

Model	Size		Pump														Shaft					wt kg	
	φ1	φ2	A	B	C	D	E	F	G	J	M	N	O	P	R	X	Z	T	Q	U	V		W
100x65 FSKA	100	65	125	360	225	280	315	120	16	80	400	160	110	150	17	285	19	38	80	8	5	10	106
150x100 FSKA	150	100	140	530	250	315	315	120	16	80	400	160	90	120	15	373	19	42	95	8	5	12	146
150x100 FSNA			180	670	375	450	450	150	20	100	550	200	140	180	19	500	24	48	110	9	5.5	14	365
200x150 FSLA	200	150	162	670	315	450	450	150	20	100	550	200	140	180	19	500	24	48	110	9	5.5	14	336
200x150 FSNA			182		375	560												60		11	7	18	488
250x200 FSLA	250	200	180	670	385	560	560	250	25	100	660	315	140	180	19	500	24	60	110	11	7	18	505
250x200 FSNA			200	820	435	630							160	200				74	125	12	8	20	642

Unit:mm, unless otherwise stated

SECTIONAL VIEW

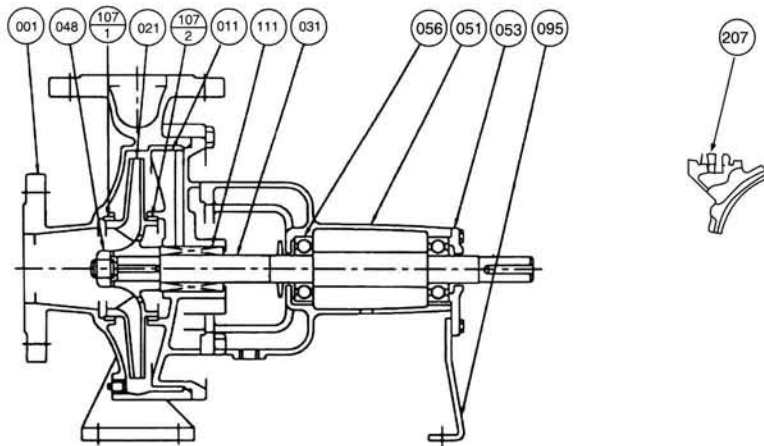

207	Plug	Steel	1
111	Mechanical Seal	-	
107-2	Casing Ring	Bronze	1
107-1	Casing Ring		
095	Stay	Steel	1
056	Ball Bearing	-	2
053	Bearing Cover	Cast Iron	1
051	Bearing Housing		
048	Impeller Nut	Brass	1
031	Shaft	Stainless Steel	
021	Impeller	Bronze	1
011	Casing Cover	Cast Iron	
001	Casing		
No.	Part Name	Material	Qty

Mechanical Seal Type (Optional)

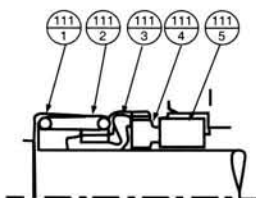

111-5	Mating Ring	Ceramic	1
111-4	Seal Ring	Carbon	
111-3	Friction Ring	NBR	
111-2	Coil Spring	Stainless Steel	
111-1	Spring Holder		
No.	Part Name	Material	Qty

Gland Packing Type (Standard)

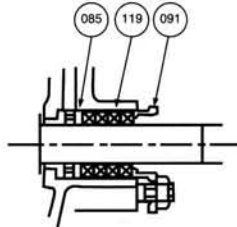

119	Gland Packing	-	4 or 5
091	Gland	Bronze	1
085	Lantern Ring Bushing		
No.	Part Name	Material	Qty

Note: All specifications are subject to change without prior notice.



PT. EBARA INDONESIA

PT. LUKES INDONESIA

Lindeteves Trade Center Lt UG, Blok B1 No. 6
 Jalan Hayam Wuruk, Jakarta - Indonesia
 Phone : 021 - 6231 7842, 628 5144
 Fax : 021 - 6231 0499
 email : lukes@cbn.net.id

