

NEW **MAGNET PUMP**

PMDseries

FOR CHEMICAL & SEA WATER

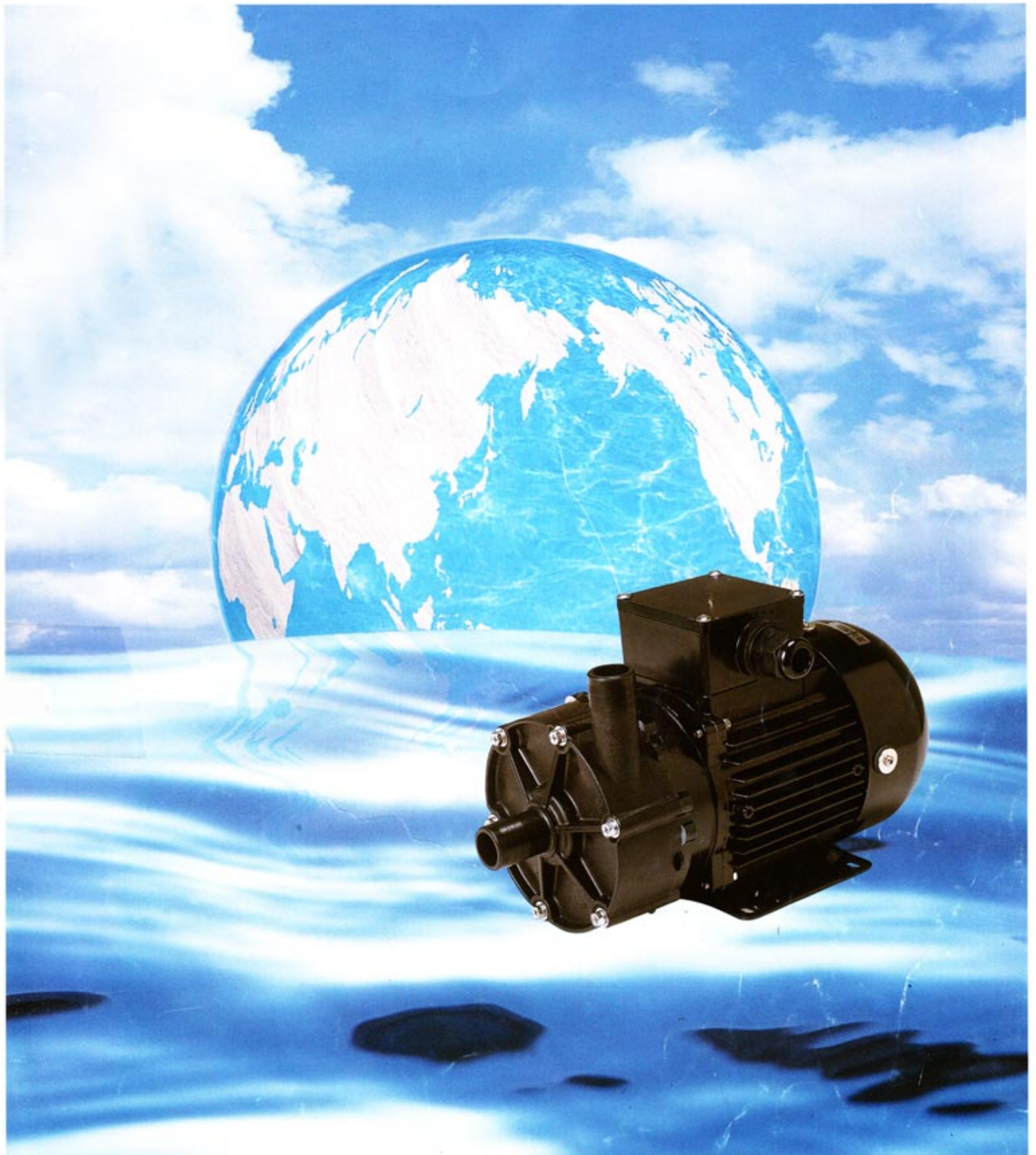

SANSO ELECTRIC CO.,LTD.

Magnet pump (For chemical & sea water)

International protection (IP44)

PMD

Magnet type

0531
221
371
421
581
641
643
1561
1563
2571
2573
4033
7533
15013
22013
37013



PMD-371

PMD-2573

PMD-4033

■ Features of new models

- Efficiency About 35% improved
- Electric power costs About 20% can be reduced
- Noise About less 5dB than conventional models
- Vibration About 50% less than conventional models
- Small and light About 10% lighter than conventional models

■ Application

- Circulation of sea water
- Culture tank and water tank
- Waste water treatment equipment
- Drain chemical liquid
- Aquarium equipment
- PCB equipment
- Solar heating system
- Filter
- Bubble bath
- Etching equipment
- Photo development equipment
- Transfer of chemical liquid
- Cooling of NC machine
- Ice maker etc.

■ Characteristics

- Magnet type
- Totally enclosed indoor type motor
- Corrosion resistance performance
- Small size and excellent performance

■ Features

- Long life
- Complete liquid leakage free
- Excellent corrosion resistance
- Varieties of models

■ Materials for pump parts

Part name	For chemical liquids & sea water
Casing	Poly-Propylene with glass fiber
Back casing	Poly-Propylene with glass fiber
Impeller	Poly-Propylene with glass fiber
Pump shaft	Ceramic
Thrust washer	Ceramic
Bearing	Teflon
O-ring	FKM (Fluoro rubber)

Structure with very simple components prevents liquid leakage and corrosion.

A Front-casing with hose-connection

Integral moulding by polypropylene mixed with filler to increase mechanical strength.

B Front-casing with screw-connection

Integral moulding as well as hose-connection type. Straight screw according to diameter as standard. Simple and compact connection to piping .

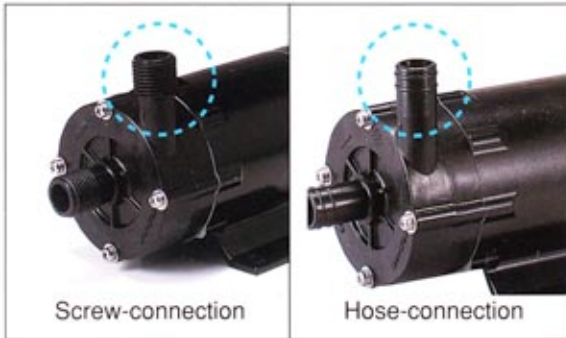

Structure and Parts Name
PMD 421

Parts Name

- ① Casing
- ② Impeller
- ③ Pump Shaft
- ④ Thrust Washer
- ⑤ Bearing
- ⑥ O-Ring

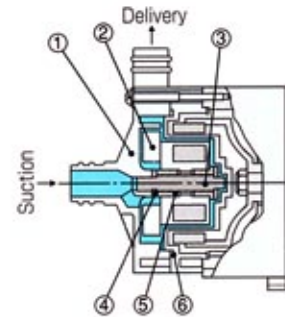

C Impeller

Material is polypropylene or PPE and permanent magnet is contained inside. Teflon or Carbon bearing is inserted between impeller and shaft. Shape of impeller is open or closed or semi-closed type, depending on performance characteristics.

D Back casing

Integral moulding by polypropylene or PPE as well as front-casing.

E Drive magnet

Made of permanent magnet magnetized from 6 poles to 10 poles. Impeller is rotated by magnet from outside of back casing.

Magnet pump (For chemical & sea water)

■ Outline dimension PMD-0531

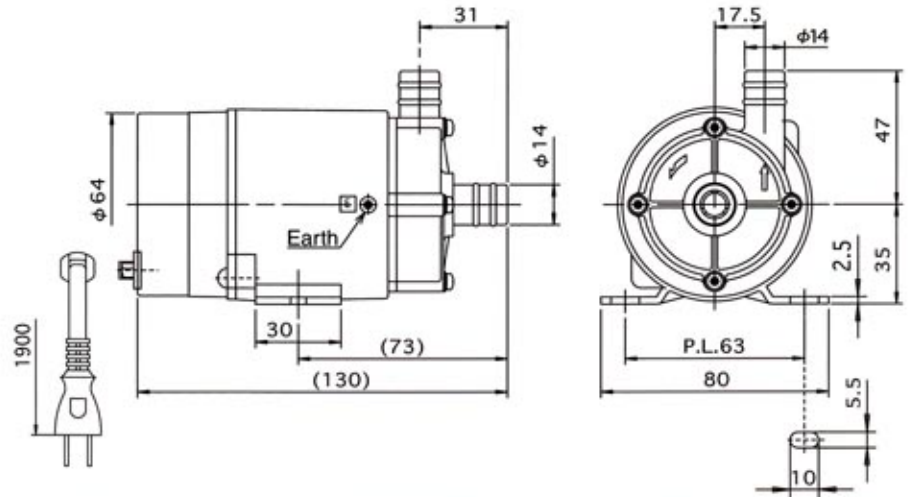

PMD-221

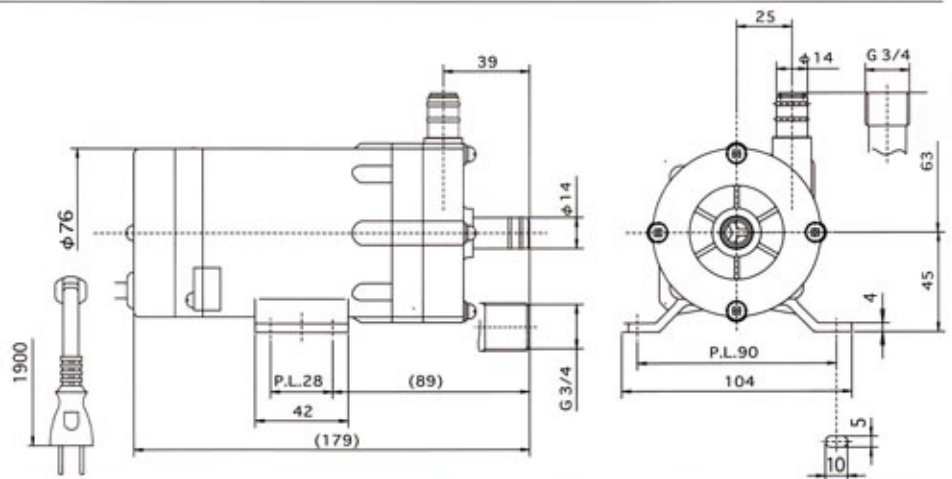

PMD-371

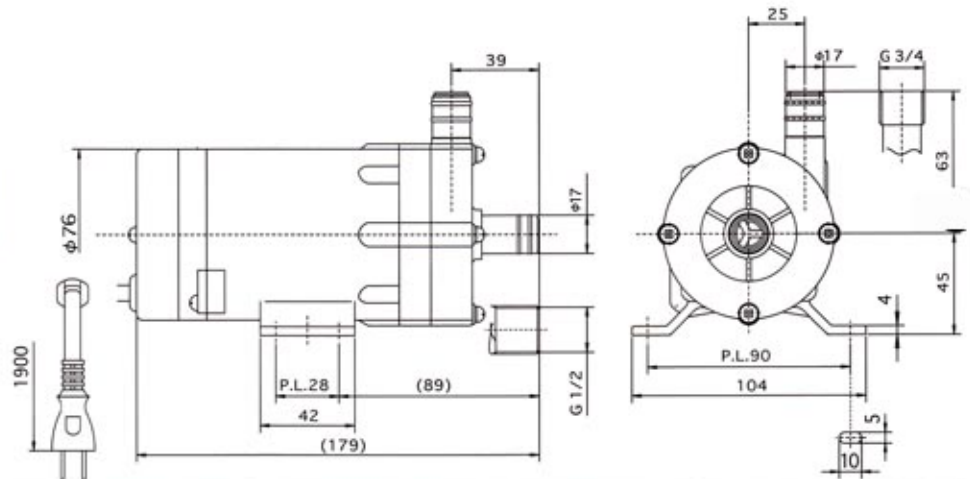

PMD-421

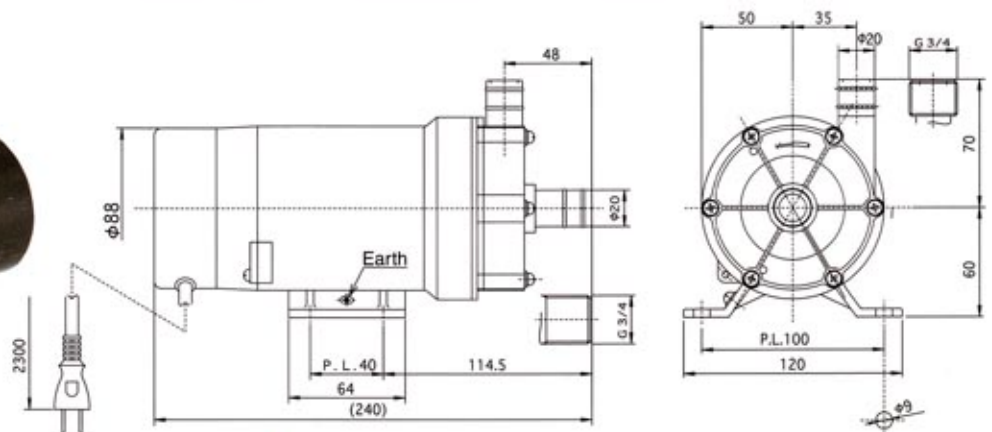

Outline dimension PMD-581

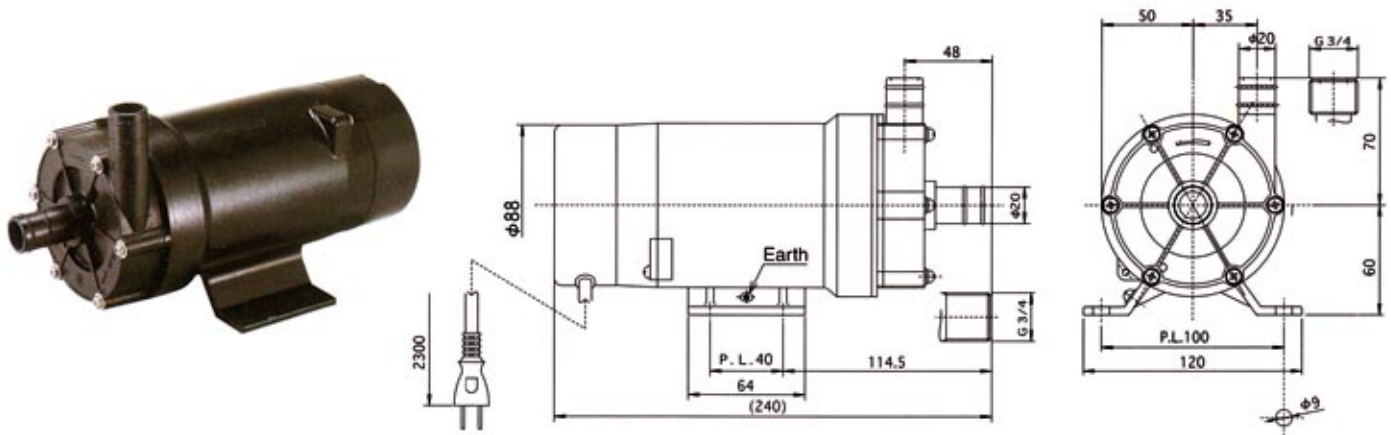

PMD-641/643

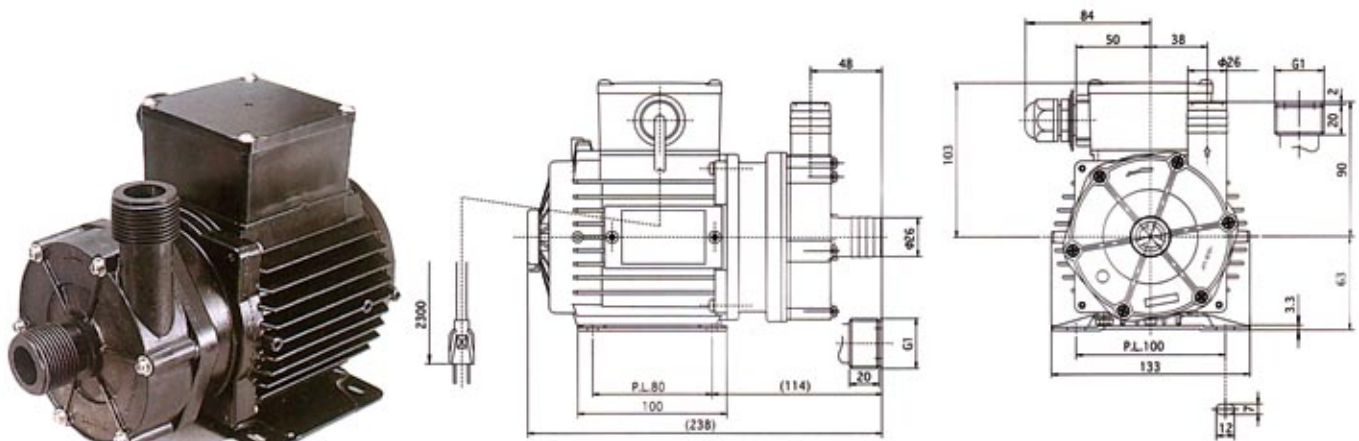

PMD-1561/1563

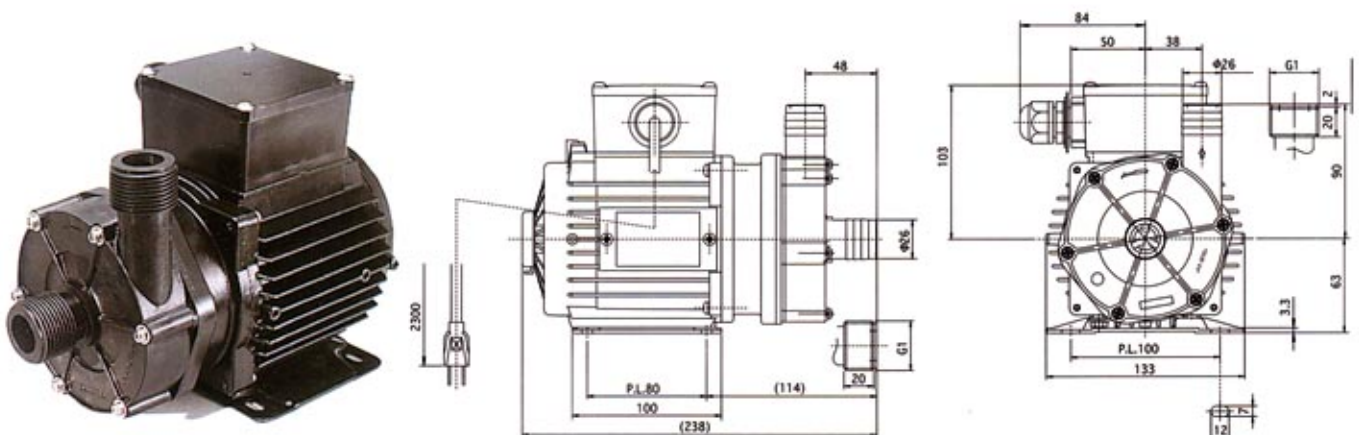

Magnet pump (For chemical & sea water)

Outline dimension

PMD-2571A.B
PMD-2573A.B

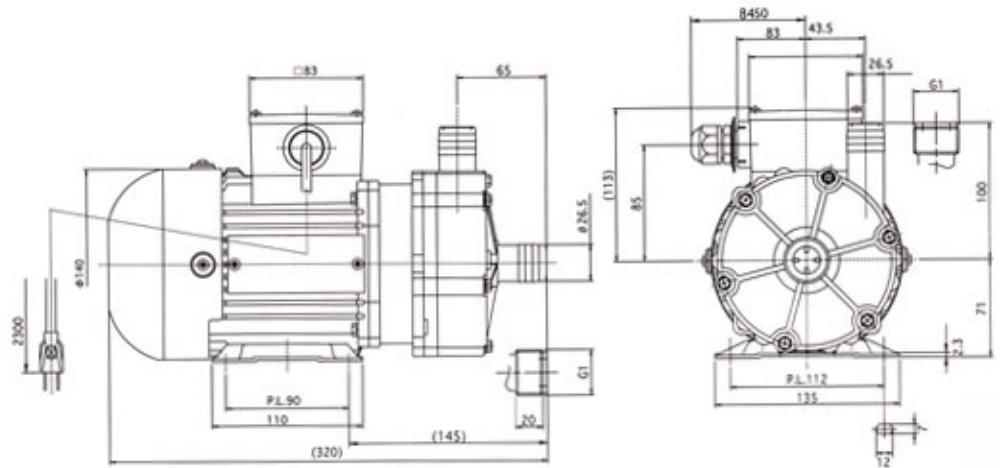

PMD-4033A.B

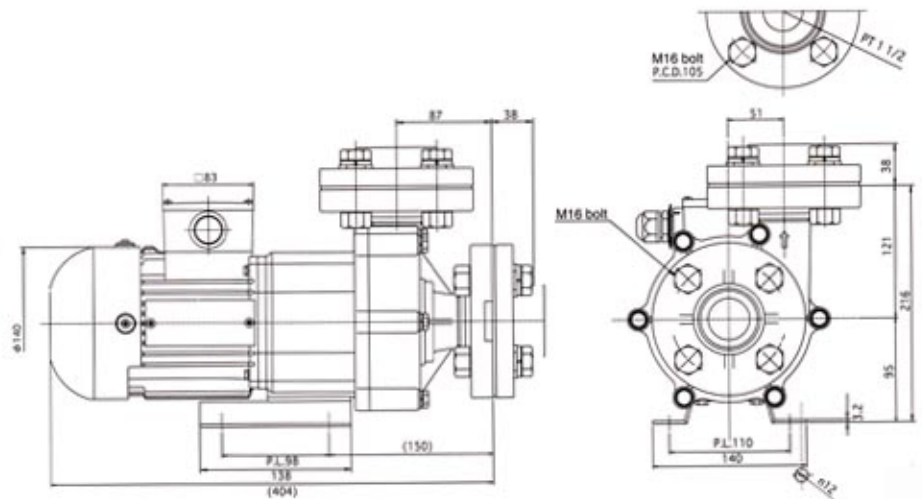

PMD-7533A.B

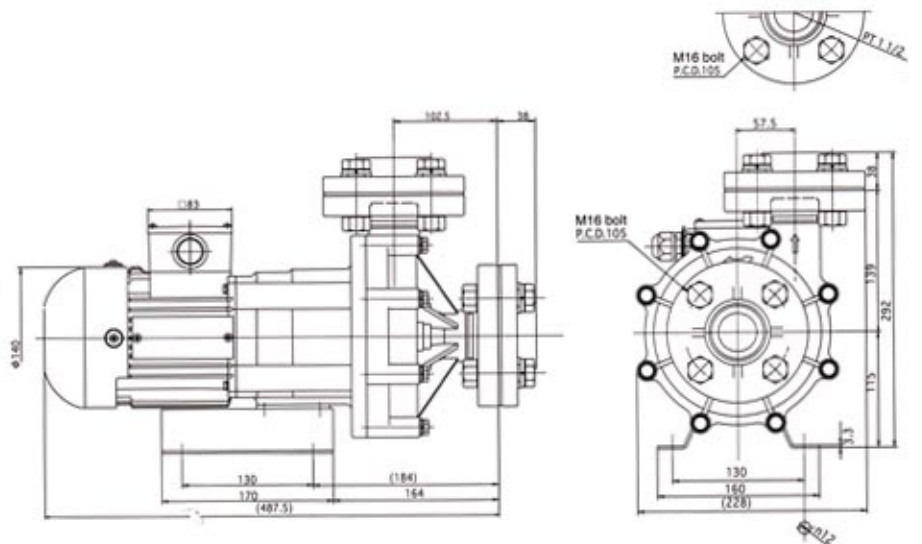
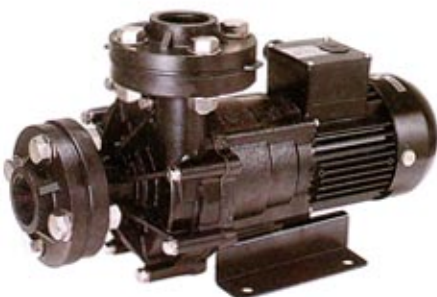

Outline

PMD-1561
PMD-1563

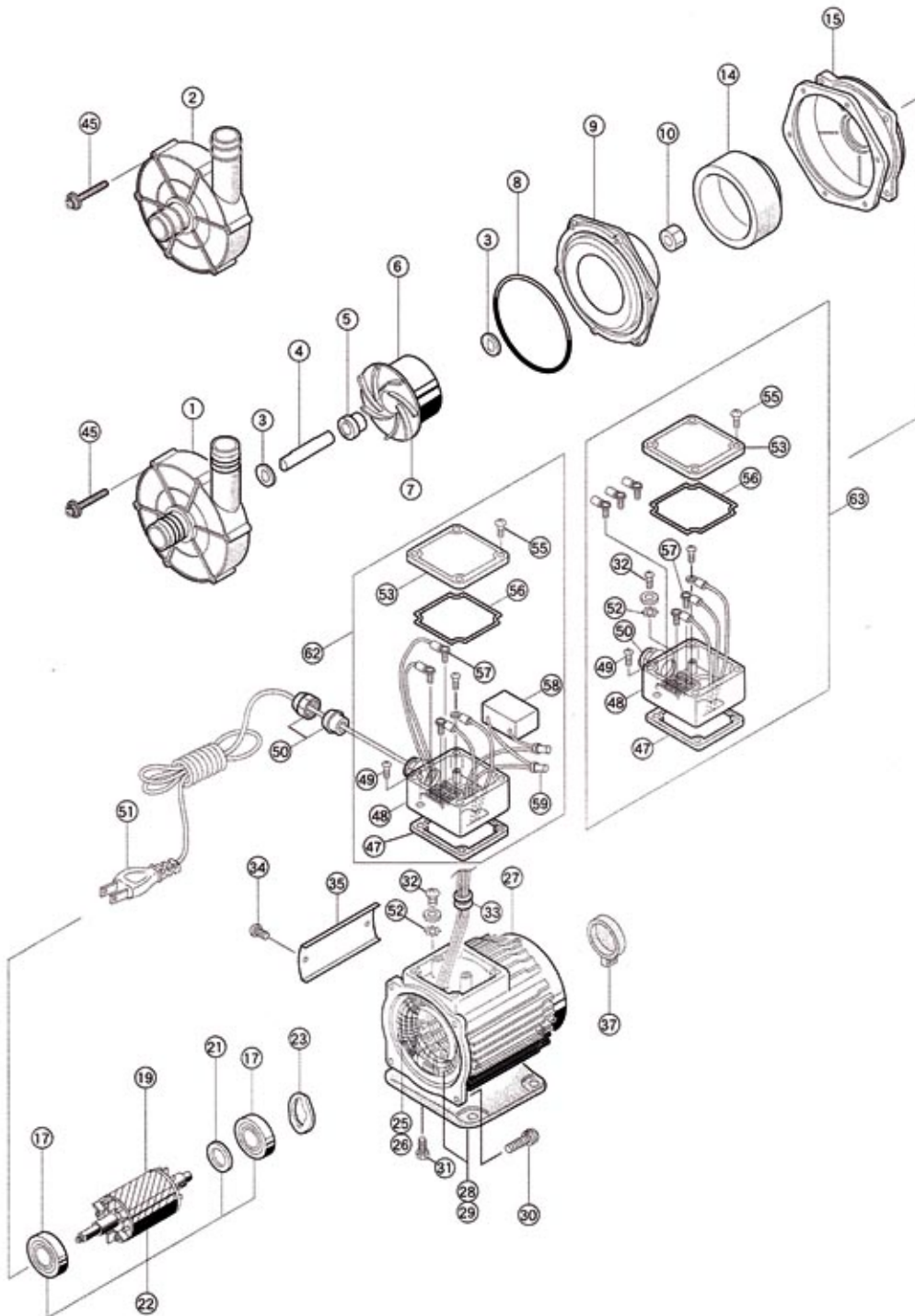

- ① casing(screw)
- ② casing(hose)
- ③ bearing washer
- ④ pump shaft
- ⑤ bearing
- ⑥ impeller assembly
- ⑦ impeller assembly
- ⑧ O-ring
- ⑨ back casing
- ⑩ nut
- ⑪ magnet housing assembly
- ⑫ bracket A
- ⑬ ball bearing
- ⑭ rotor
- ⑮ thrust washer
- ⑯ rotor assembly
- ⑰ preload spring
- ⑱ stator assembly for 100V
- ⑲ stator assembly for 200V
- ⑳ case B
- ㉑ case B assembly for 100V
- ㉒ case B assembly for 200V
- ㉓ screw (4P+16U)
- ㉔ bolt (6R+12S)
- ㉕ earth
- ㉖ cord bush
- ㉗ screw (for fixing the name plate)
- ㉘ plate for fixing the name plate
- ㉙ shaft cover
- ㉚ screw (for casing)
- ㉛ terminal box packing for motor
- ㉜ terminal box
- ㉝ screw
- ㉞ anti-water bush
- ㉟ power source cord assembly
- ㊱ washer
- ㊲ terminal box cover
- ㊳ screw
- ㊴ terminal box packing(with cover)
- ㊵ terminal
- ㊶ condenser
- ㊷ connector
- ㊸ terminal box assembly for 100V
- ㊹ terminal box assembly for 200V
- ㊺ motor assembly(15 to 28)for 100V
- ㊻ motor assembly(16 to 29)for 200V

Magnet pump (For chemical & sea water)

Performance curve(50Hz)

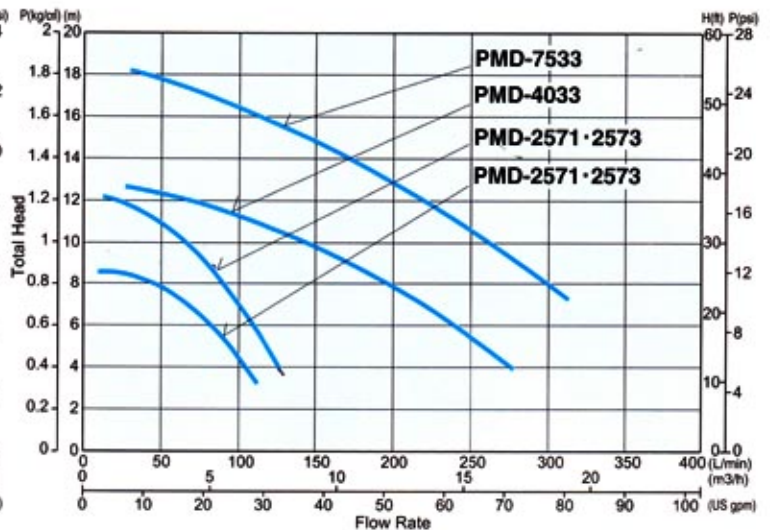
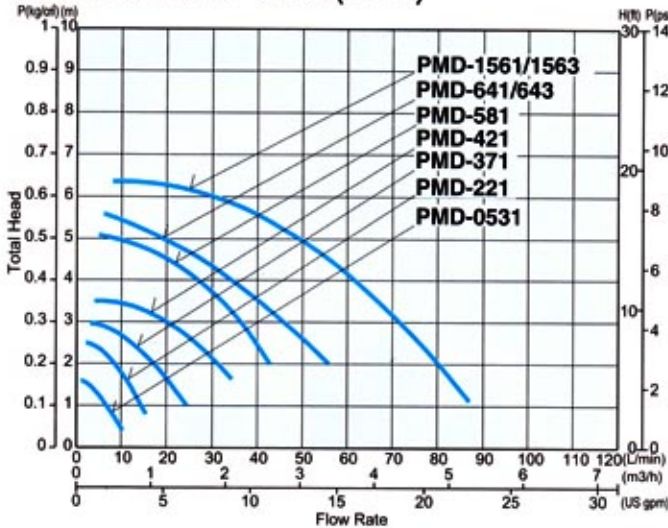

Performance curve(60Hz)

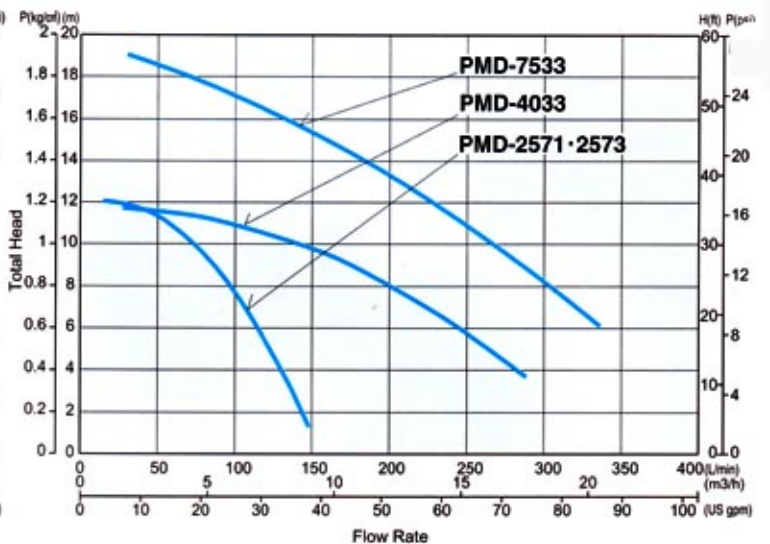
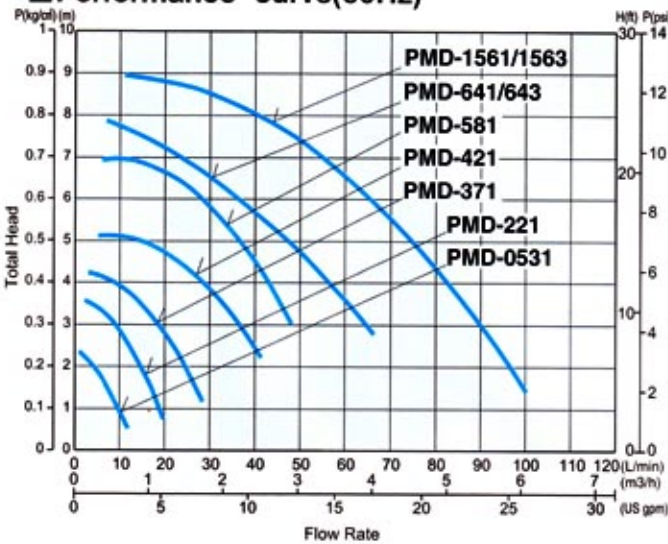

Specification : Last figure of model name : 1 means single phase and 3 means three phase.

Model	Item	Diameter		Maximum		Rated Flow Rate		Motor			Weight kg
		Hose A(mm)	Screw B(G-)	Flow Rate L / min	Head m	5 0 Hz / 6 0 Hz		Rated Output W	Power Consumption W	Voltage V	
						m- L / min					
PMD-0531		14	—	10 / 12	1.7 / 2.5	1-6 / 1-9		4 / 6	18 / 20	100	0.7
PMD-221		14	3/4	15 / 20	2.5 / 3.6	1-13 / 2-13		10 / 15	22 / 30	100	1.7
PMD-371		17	3/4	25 / 28	3.0 / 4.2	2-18 / 3-19		15 / 20	32 / 43	100	1.7
PMD-421		20	3/4	35 / 42	3.5 / 5.1	3-21 / 4-26		35 / 45	55 / 75	100	3.4
PMD-581		20	3/4	43 / 48	5.1 / 6.8	3-35 / 5-35		40 / 60	70 / 110	100	3.4
PMD-641		26	1	62 / 72	5.7 / 8.0	3-50 / 5-50		65 / 100	105 / 155	100	4.8
PMD-643		26	1	62 / 72	5.7 / 8.0	3-50 / 5-50		65 / 100	100 / 150	200	4.7
PMD-1561		26	1	87 / 100	6.3 / 8.9	4-60 / 6-63		120 / 160	160 / 230	100	5.4
PMD-1563		26	1	87 / 100	6.3 / 8.9	4-64 / 6-70		120 / 160	160 / 240	200	5.0
PMD-2571(50Hz)		26.5	1	125 / —	12.3 / —	8-75 / —		250 / —	430 / —	100	8.0
PMD-2571(60Hz)		26.5	1	115 / 150	8.6 / 12	4-90 / 8-80		150 / 250	270 / 410	100	8.0
PMD-2573(50Hz)		26.5	1	125 / —	12.3 / —	8-75 / —		250 / —	410 / —	200	7.5
PMD-2573(60Hz)		26.5	1	115 / 150	8.6 / 12	4-90 / 8-80		150 / 250	260 / 400	200	7.5
PMD-4033(50Hz)		40	1-1/2	300 / —	12.3 / —	10-140 / —		400 / —	540 / —	200	17.0
PMD-4033(60Hz)		40	1-1/2	250 / 300	8.2 / 11.6	6-120 / 10-140		250 / 400	450 / 700	200	17.0
PMD-7533(50Hz)		40	1-1/2	380 / —	18.2 / —	12-210 / —		750 / —	901 / —	200	21.0
PMD-7533(60Hz)		40	1-1/2	330 / 380	13.4 / 19	7-220 / 12-225		450 / 750	601 / 1000	200	21.0

Conditions of liquids : Ambient Temp : 0 to 60°C Viscosity : below 30mm²/s, Specific Gravity : below 1.1

Note (1) Slurry liquids reduce life of pump. (2) Pressure shall be less than 100kPa. (3) Indoor use.

(4) Shock pressure and abnormal pressure etc will damage the pump part. (5) Voltage can be adjusted to customer's requirement.

Excellent characteristics

Shaft

- Endurance of shaft is much improved because of being supported from both sides.
- Shaft can be changed individually.
- SIC with excellent endurance is available, if required.

Back casing

- Special structure of rear casing and structure of impeller for preventing the air retention is excellent against the air lock.
- Endurance of rear casing is much improved, because carbon fiber is used for reinforcing the rear casing.

Exclusive motor (with terminal box)

- This pump can be used in the chemical environment, because reinforced plastics is used for terminal box.
- Wiring works are easy, because terminal box is equipped at the upside of pump.
- Oil seal is used against gas and liquid leakage to prevent the motor corrosion. Lifetime is much improved.

Impeller and magnet

- Strong rare earth magnet is used for over 1.5Kw.
- Problem in high temperature and reverse rotation can be prevented, because impeller and magnet is coupled.
- Efficiency is improved because of special impeller.

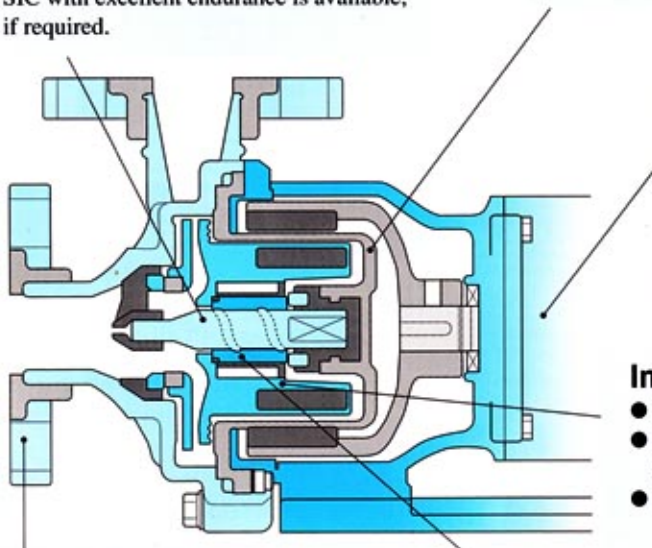

Loose flange

- Loose flange is used to be adjusted to the opposite side.

Bearing

■ Performance curve(50Hz)

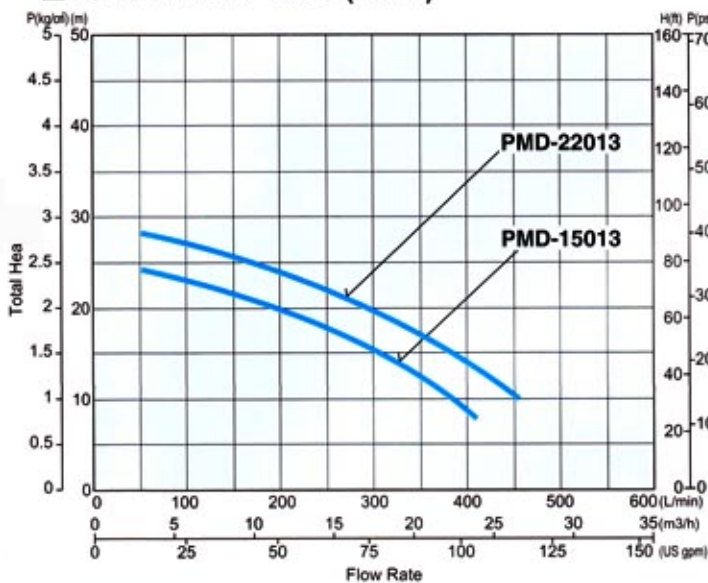

■ Performance curve(60Hz)

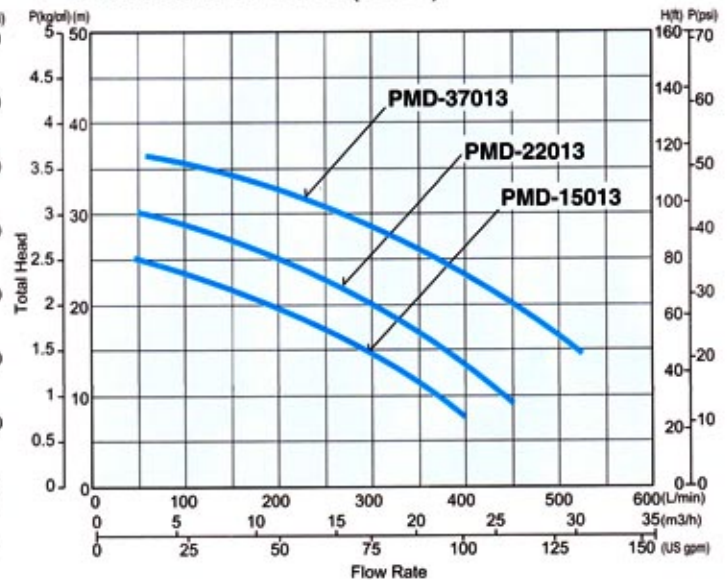

■ Specification

Model	Item	Diameter	Maximum		Rated Flow Rate	Motor			Weight
			Flow Rate	Head		Rated Output	Power Consumption	Voltage	
PMD-15013(50Hz)		50A×40A	430	26	m ³ -L / min	1.5	1.7	200	27.0
PMD-15013(60Hz)		50A×40A	420	26		1.5	1.6	200	27.0
PMD-22013(50Hz)		50A×40A	480	30		1.9	2.2	200	29.0
PMD-22013(60Hz)		50A×40A	470	32		1.9	2.2	200	29.0
PMD-37013(60Hz)		50A×40A	550	39		3.0	3.7	200	52.0

Note (1) PMD-37013(50Hz) is not available. (2) Voltage can be adjusted to customer's requirement.

Outline

PMD-15013
PMD-22013

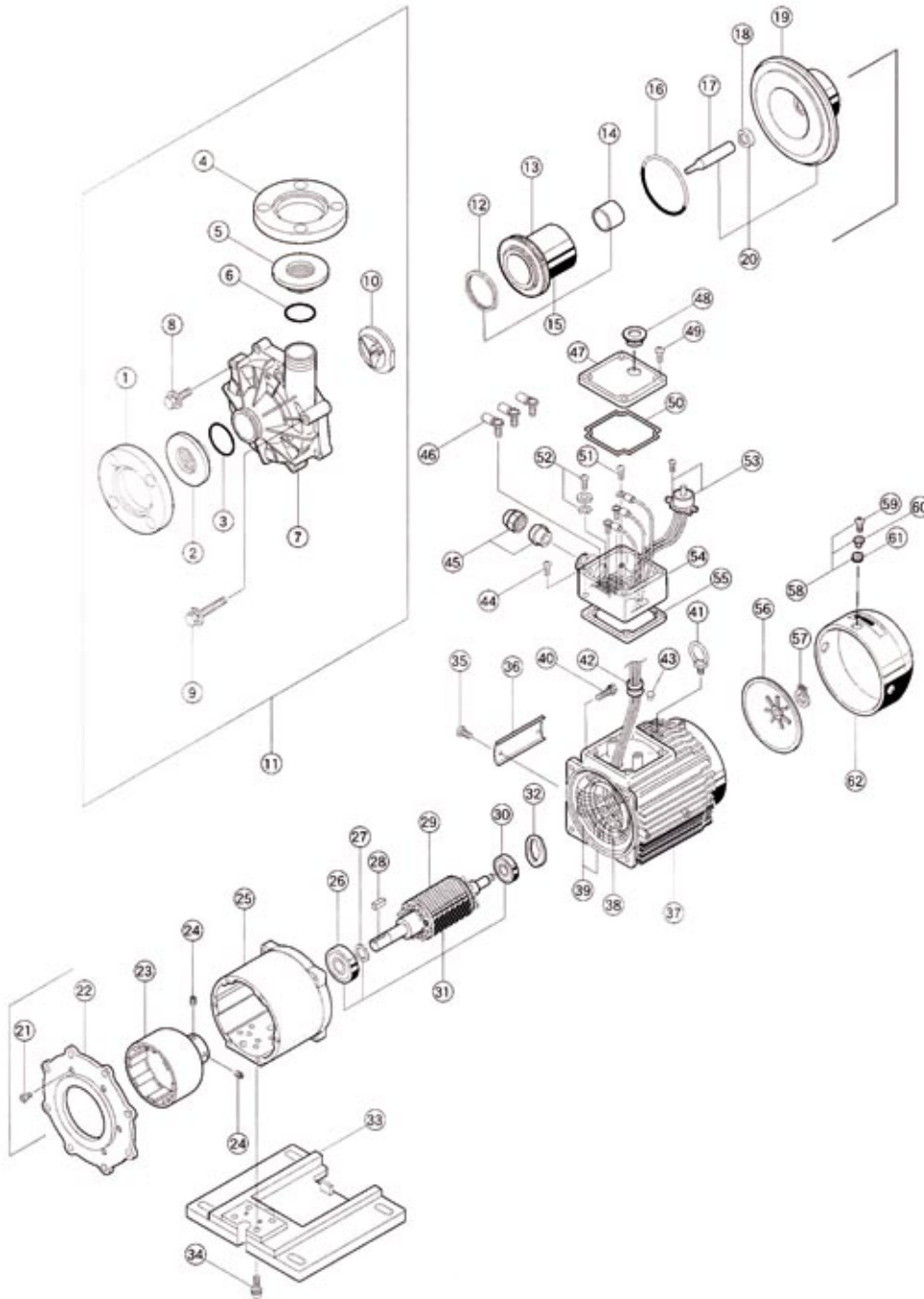

- ① flange fitting(suction side)
- ② wrap joint(suction side)
- ③ O-ring(suction side)
- ④ flange fitting(discharge side)
- ⑤ wrap joint(discharge side)
- ⑥ O-ring(discharge side)
- ⑦ casing
- ⑧ bolt for casing(M10×35)
- ⑨ bolt for casing(M10×65)
- ⑩ lining
- ⑪ casing assembly
- ⑫ mouth ring
- ⑬ impeller
- ⑭ bearing
- ⑮ impeller assembly
- ⑯ O-ring
- ⑰ pump shaft
- ⑱ rear thrust ring
- ⑲ rear casing
- ⑳ rear casing assembly
- ㉑ M6×12 bolt with hexagonal hole for supporting
- ㉒ rear casing support
- ㉓ magnet housing assembly
- ㉔ screw with hexagonal hole for magnet housing assembly
- ㉕ bracket assembly
- ㉖ ball bearing
- ㉗ thrust washer
- ㉘ key
- ㉙ rotor
- ㉚ ball bearing
- ㉛ rotor A
- ㉜ preload spring
- ㉝ base
- ㉞ bolt M8×25 with hexagonal hole for base
- ㉟ screw for fixing the name plate for name plate, 4P+8S
- ⓫ plate for fixing the name plate
- ⓬ case B
- ⓭ stator
- ⓮ case B assembly
- ⓯ hexagonal bolt with cross recess, 6R+25u with SWS
- ⓰ eye bolt
- ⓱ cord bush
- ⓲ set pin
- ⓳ screw for fixing the terminal box 4P+12S
- ⓴ bush for preventing the water
- ⓵ terminal
- ⓶ cover for terminal box
- ⓷ cover for reset (option)
- ⓸ screw for fixing the terminal box cover, 4T+16u
- ⓹ packing for terminal box(cover side)

- ⓺ screw for fixing the anti-vibration rubber 4P+12u
- ⓻ color for anti-vibration rubber
- ⓼ anti-vibration rubber
- ⓽ cover for outer fan

- ⓾ screw for fixing the terminal with 4P+10 SWS WS
- ⓿ earth
- ⓿ protector (option)
- ⓿ terminal box
- ⓿ packing for terminal box(for motor)
- ⓿ outer fan
- ⓿ C-ring
- ⓿ anti-vibration rubber assembly

Note : ⑪ ⑱ ㉑ are completed assembly and each part of assembly can't be supplied for services.



SANSO ELECTRIC CO.,LTD.

1-1, Aoyama-Kita, 1-Chome, Himeji-City, 671-2288, Japan
TEL.81-79-266-1200 FAX.81-79-266-1206
E-MAIL sanso@sanso-elec.co.jp
URL <http://www.sanso-elec.co.jp>

Distributed by;

PT. LUKES INDONESIA

Lindeteves Trade Center Lt UG, Blok B1 No. 6
Jalan Hayam Wuruk, Jakarta - Indonesia
Phone : 021 - 6231 7842, 628 5144
Fax : 021 - 6231 0499
email : sales@lukesindonesia.com

